

## Ветка рябины

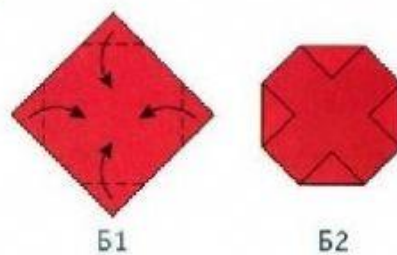

## ВОРОБЕЙ

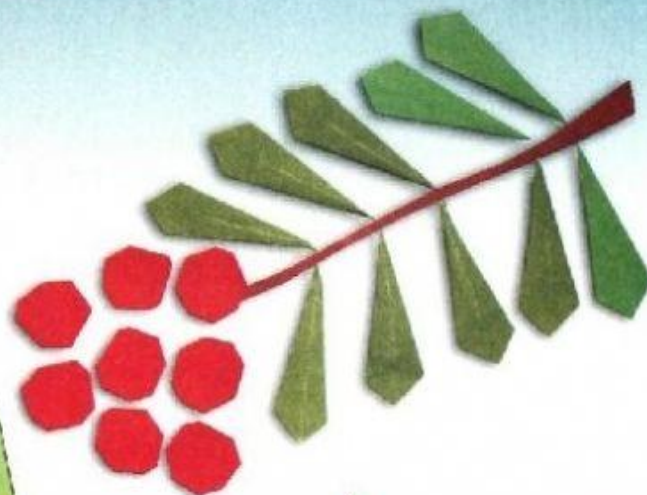
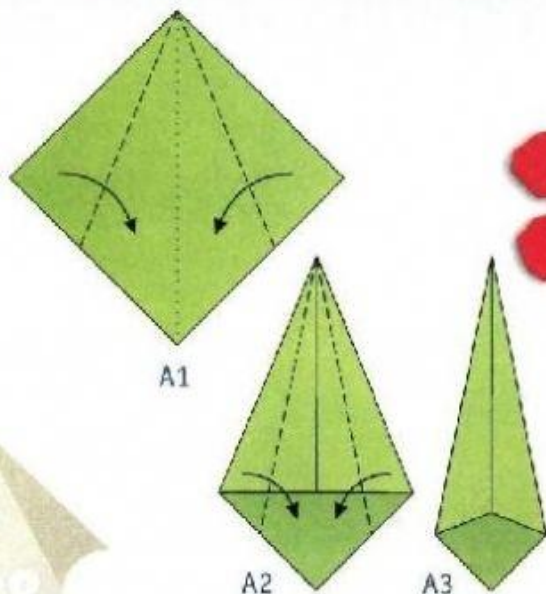
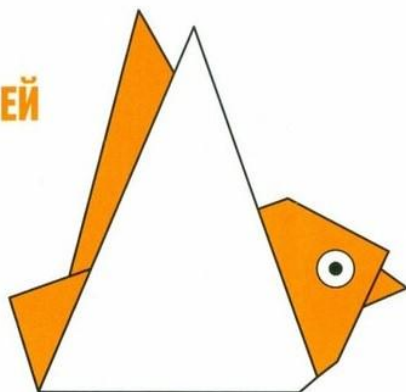

1. Наметьте диагональ квадрата.
2. Разрежьте по линии сгиба.
3. Используйте один из двух получившихся треугольников.
4. Наметьте вертикальную линию складки. Переверните на другую сторону.
5. Выполните складку, совместив угол с серединой противоположной стороны.
6. Согните второй угол.
7. Сложите фигурку по вертикальной линии, освобождая при этом оба сложенных угла.
8. Опустите указанный угол вниз.
9. Поднимите угол.
10. Выполните указанную складку.
11. Поднимите угол вверх.
12. Выполните складку «зигзаг» по намеченным складкам.
13. Подогните небольшие углы снизу.
14. Воробей готов!

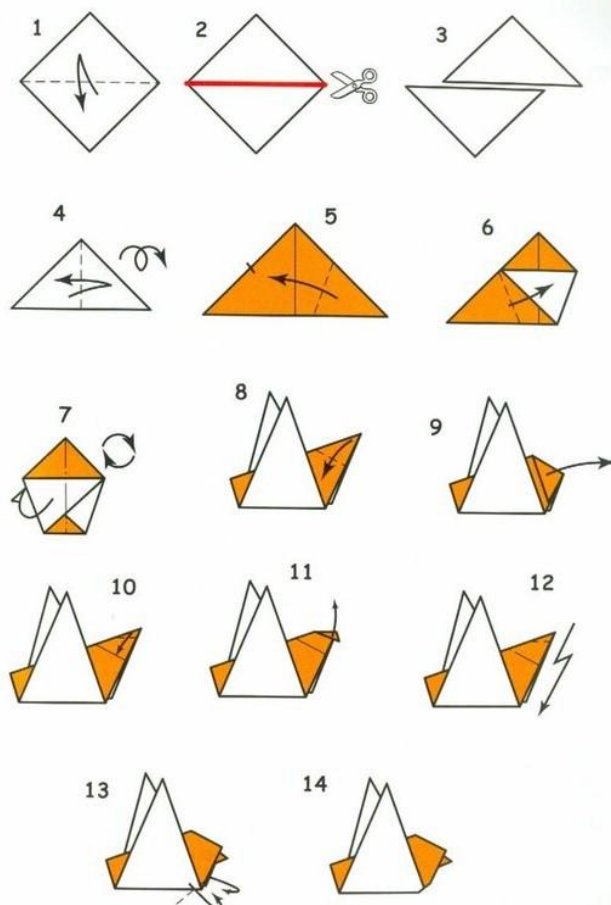

# ДОМИК

1

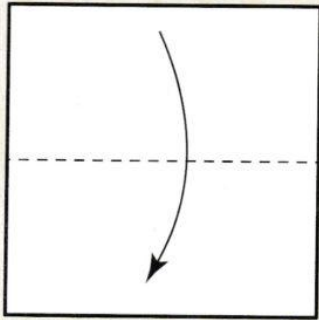

2

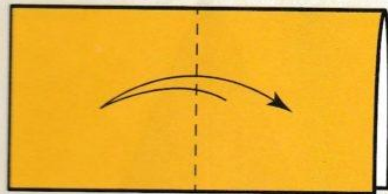

3

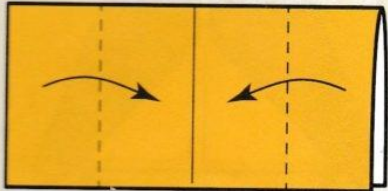

14

4

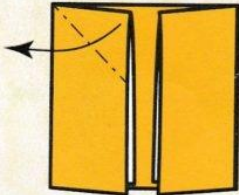

5

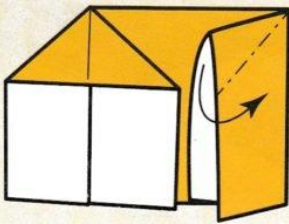

6



# Кролик

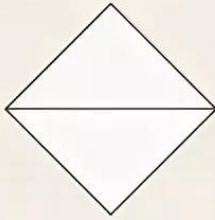

1.

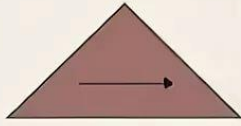

2.

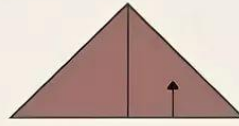

3.

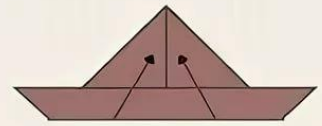

4.

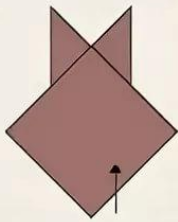

5.

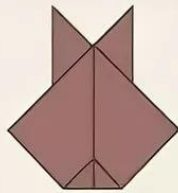

6.

Перевернуть

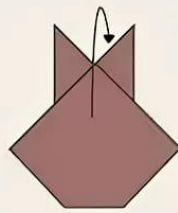

7.

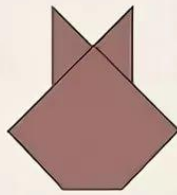

8.

Нарисовать (приклеить)  
глаза, нос, рот, усы

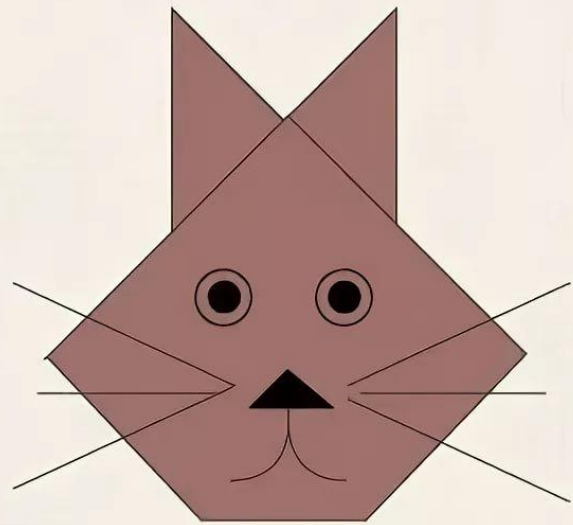

Результат

## Кузнечик

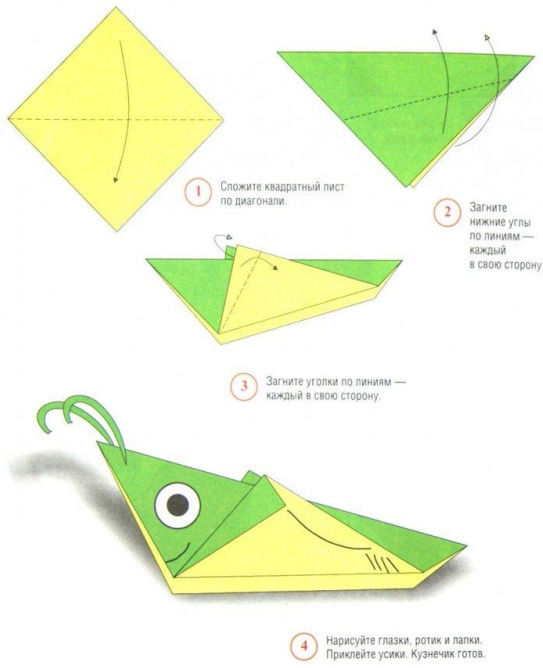

8

## Гномик

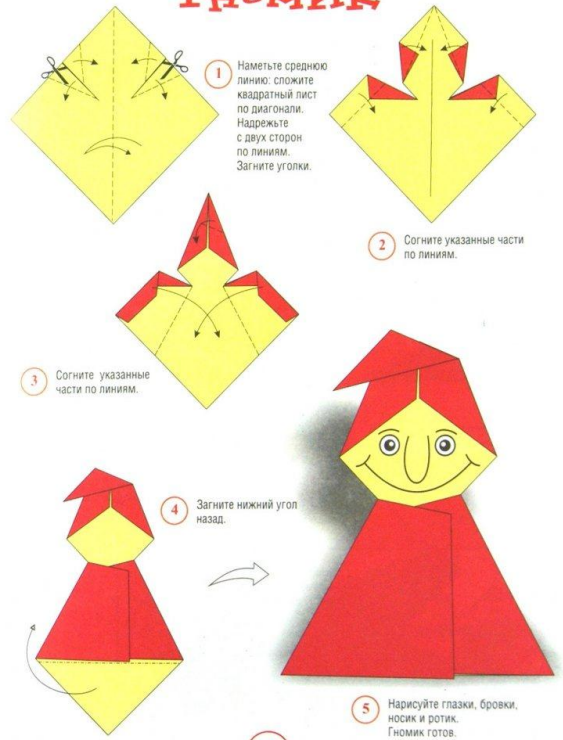

9

## Лиса

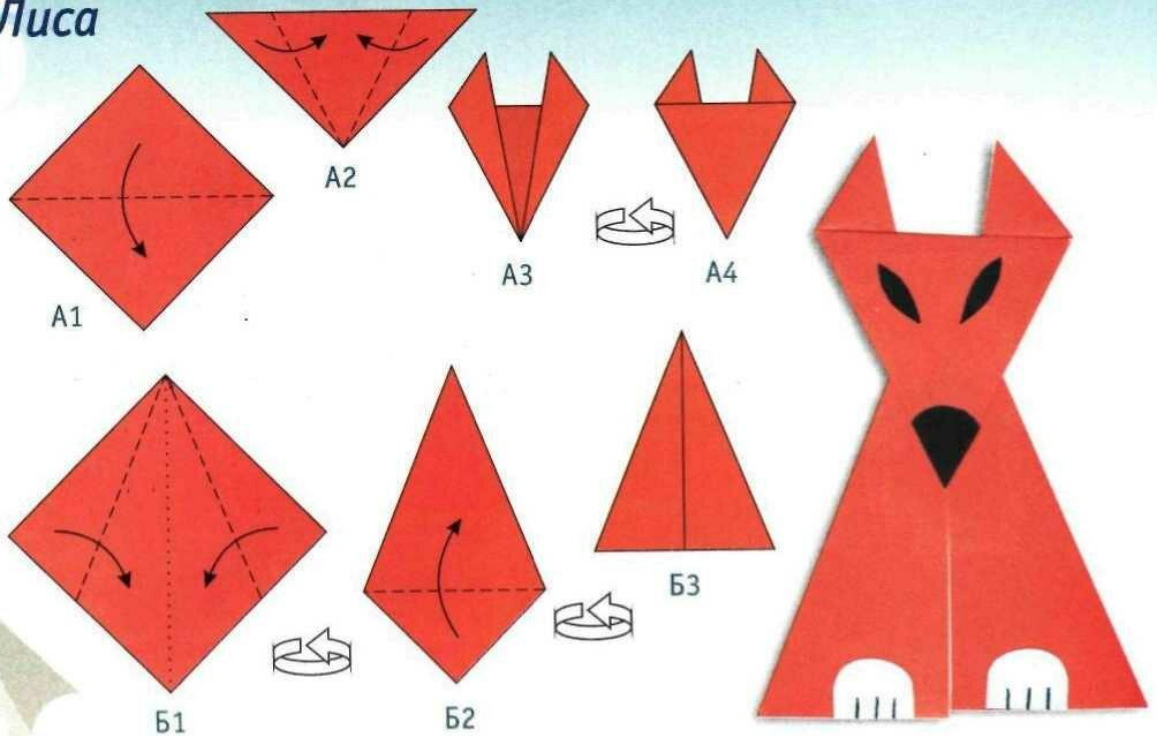

# 49 Лодочка

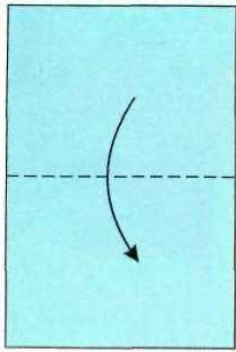
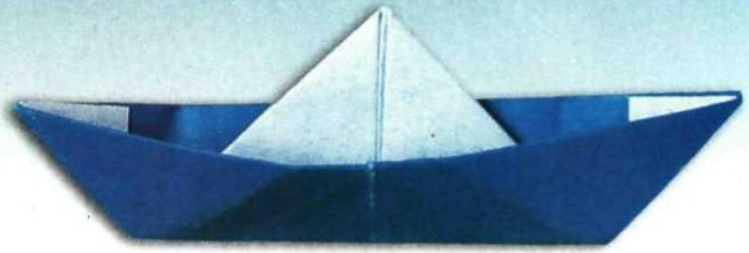

1

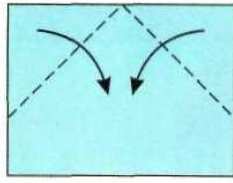

2

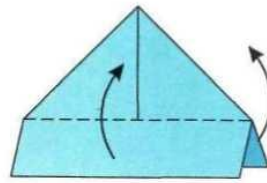

3

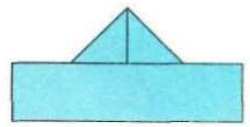

4

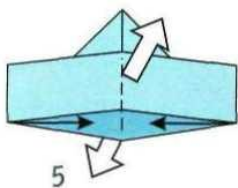

5

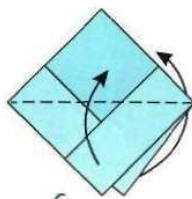

6

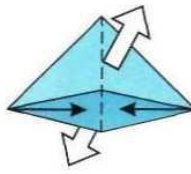

7

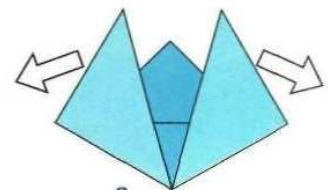

8

50

# 1 Лягушка

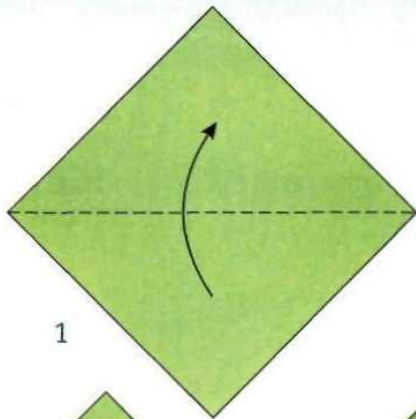

1

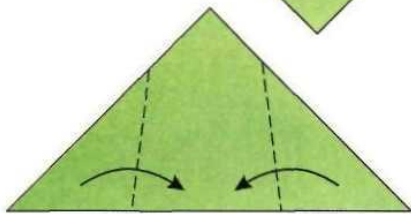

2

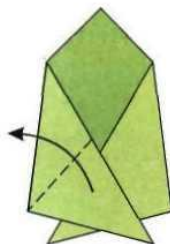

3

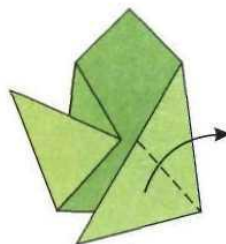

4

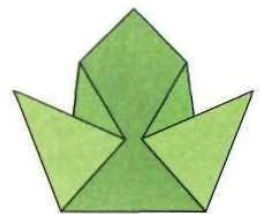

5

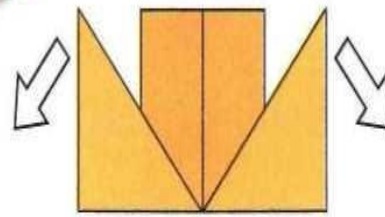
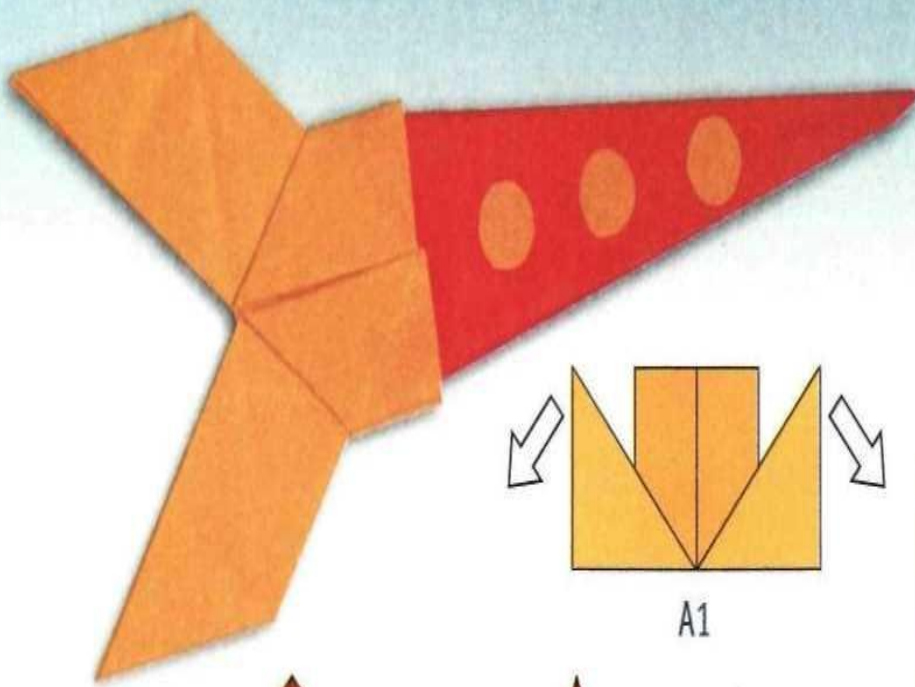

A1

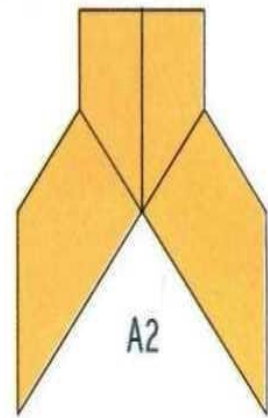

A2

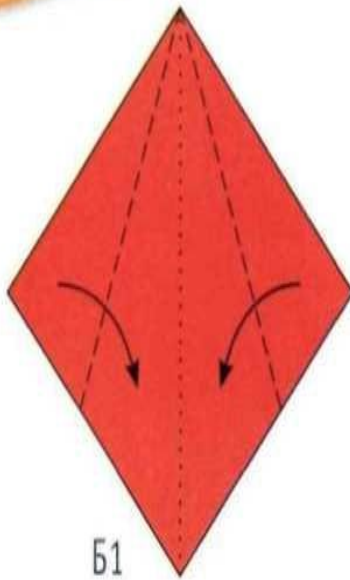

B1

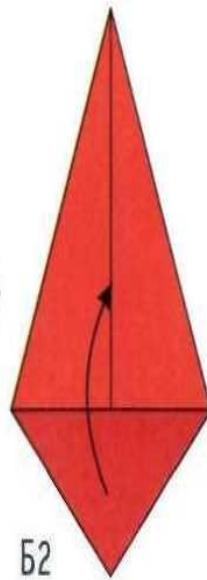

B2

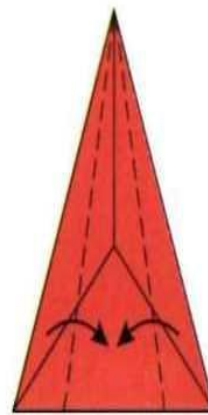

B3



B4

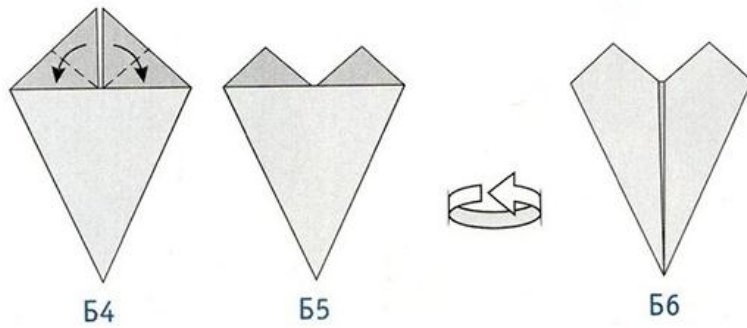
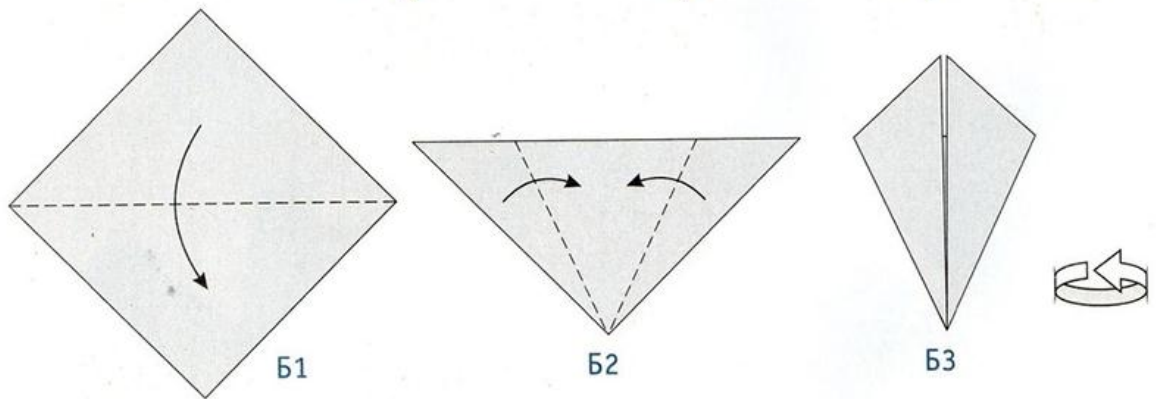
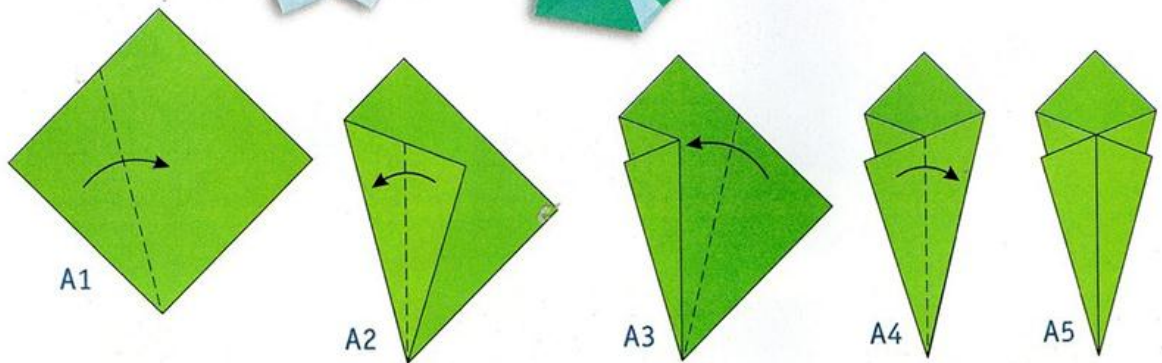
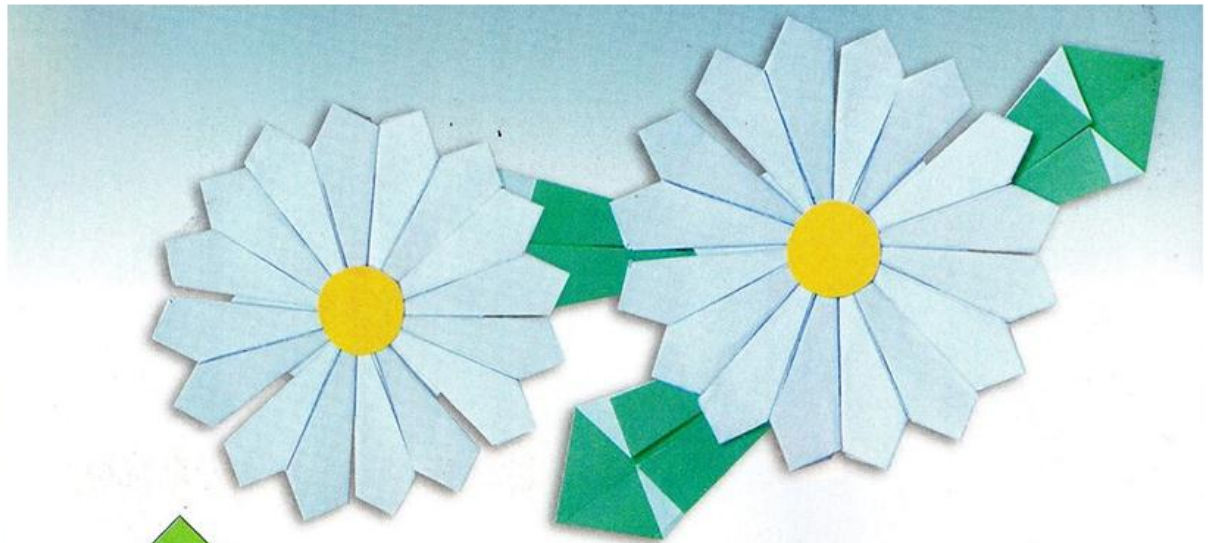

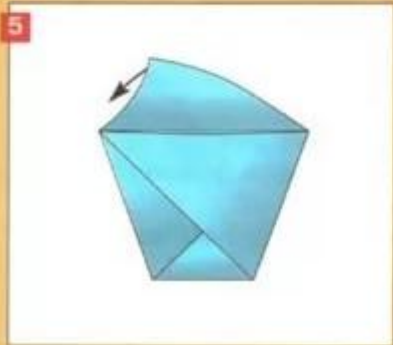
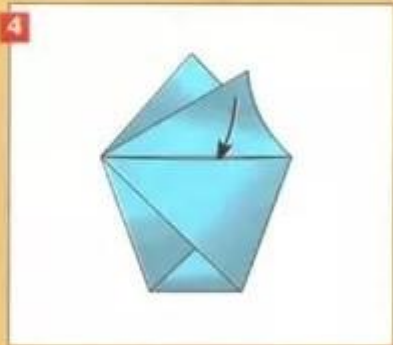
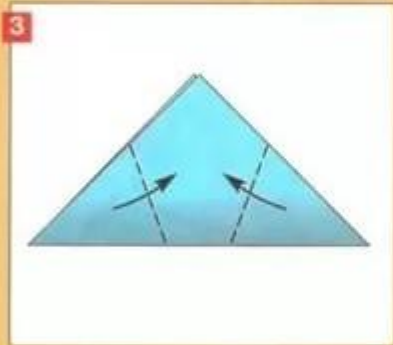
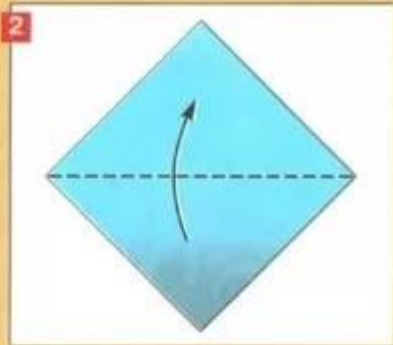
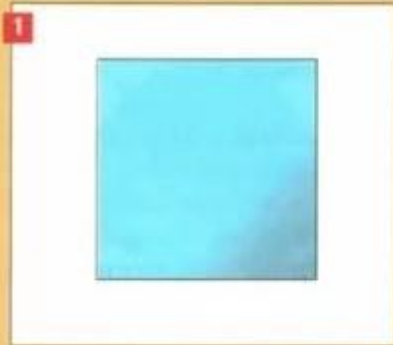



Тело (т)

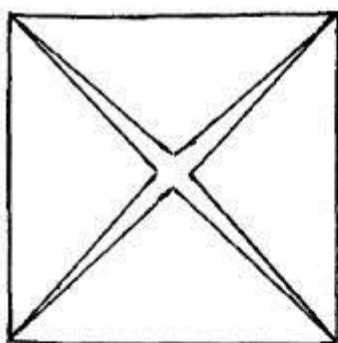

1т

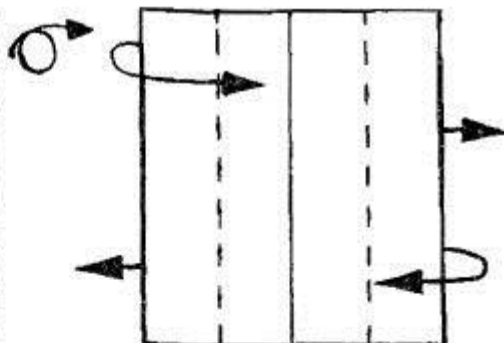

2т

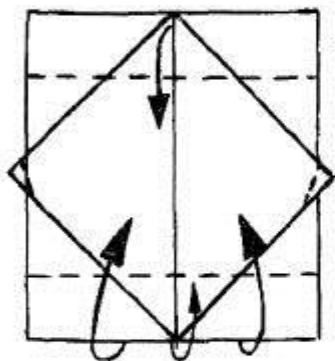

3т

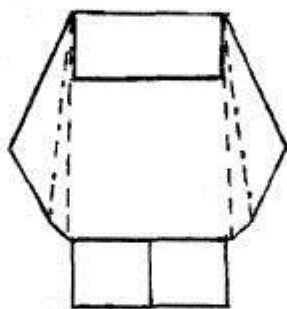

4т

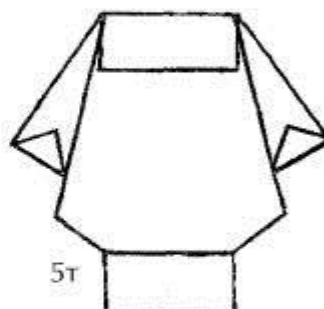

5т

Сборка

Голова (г)

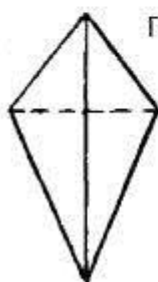

1г

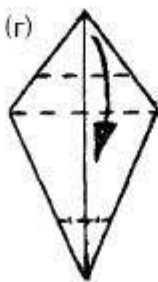

2г

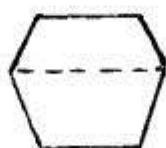

3г



Тюльпан и бутон розы

34

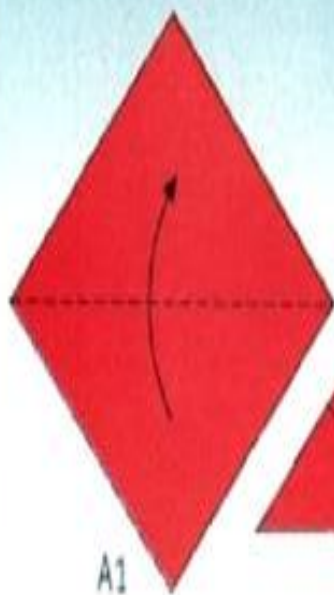

A1

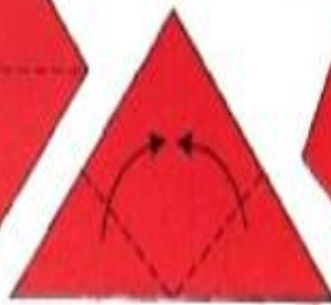

A2



A3



B1

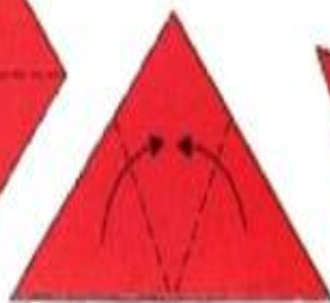

B2



B3



# Хризантема

37

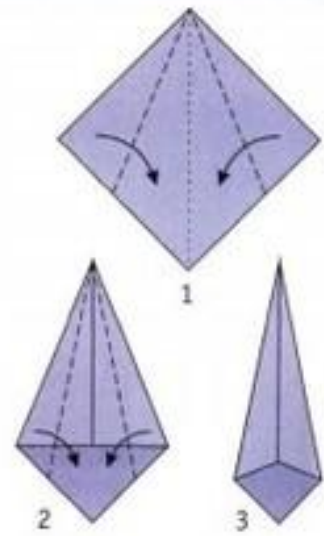

2

1

3

# Колокольчики

38

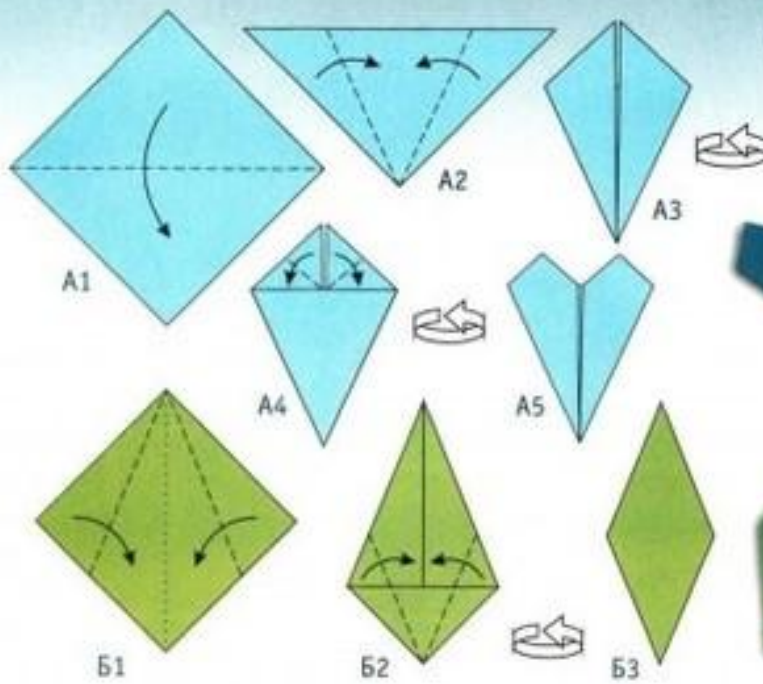

A1

A2

A3

A4

A5

B1

B2

B3



41

